

Non-contact level measurement sensor

InoxLaser NL-01

Product overview

The NEWCO Instruments InoxLaser is a non-contact laser sensor used to measure the distance to a solid surface. This surface could be anything from a flat metal plate on the side of an overhead crane, to the top of material stored in a silo. With an easy to use menu system, the InoxLaser can be configured for either distance or level measurement and the high accuracy, long range and fast update rate make this the ideal sensor for many different applications.

Features

- o Non-contact measurement with laser technology
- o 303 Stainless steel housing
- o Measurement range up to 50 meters (164 feet)
- o Continuous measurement with a resolution of 10 mm
- o NAMUR compliant 4...20 mA output
- o 2 Normally open relay outputs
- o Easy configuration via USB



Level, distance & position measurement of solids

Applications

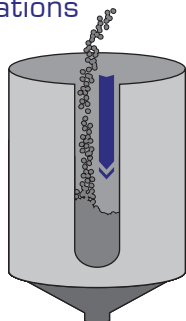

Level control

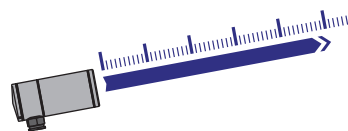

Distance measurement

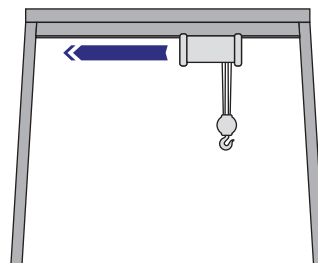

Positioning

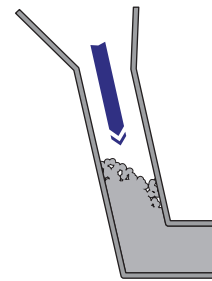

Blockage detection

Technical specifications

Performance data

Sensing range	0.3...50 m (0.98...164')
Resolution	1 cm (0.39")
Accuracy	< 0.1% of full range at 20°C
Update rate	5 readings per second

Technical data

Power supply	24 V dc nominal (12...28 V dc)
Current consumption	100 mA nominal

Output

Analog	4...20 mA NAMUR compliant self-powered & non-isolated. 2 x Relays (N/O), 250 V at 3 A.
Communication	USB at 115200 baud 8-N-1

Mechanical data

Diameter	NL-01: 6.35 cm (2.36")	NL-01/DT: 14 cm (5.51")
Length	NL-01: 14.4 cm (5.51")	NL-01/DT: 11 cm (4.33")
Weight	NL-01: 1 kg (2.2 lb)	NL-01/DT: 0.75 kg (1.65 lb)
Connection	Flange accessory (NL-01/DT) with 4 Ø 0.85 cm holes on 120 PCD	
Housing material	303 Stainless steel	

Optical data

Optical aperture	6 cm (2.36")
Beam divergence	< 1° to half power points
Lens material	Impact resistant acrylic
Laser safety classification	Class 1M CAUTION: Do not view laser directly with optical instruments

Environmental data

Operating temperature	-20°C...+60°C
Pressure	Atmospheric
Enclosure rating	IP66

Simple solid level measurement

Dimension drawings

NL-01

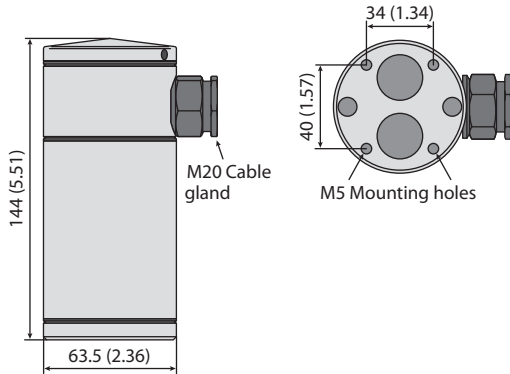

NL-01/DT

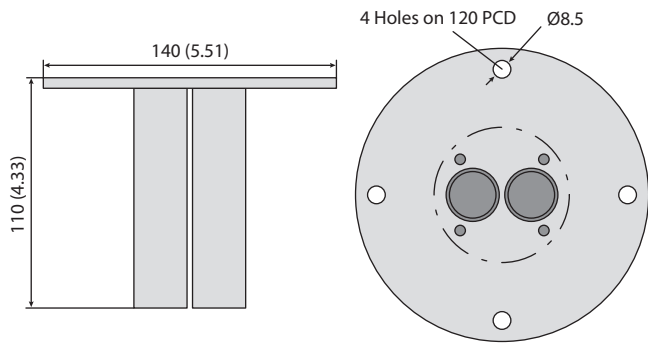

unit in millimeter (inch)

Connections

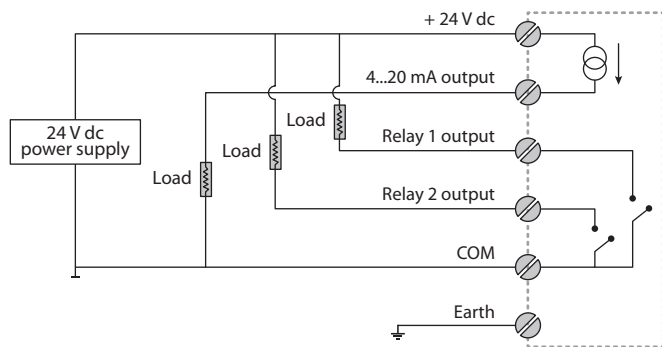

Warranty and liability statement

This product is subject to the normal terms, conditions, warranties and disclaimers of NEWCO Instruments, its distributors and representatives.

Product order codes

Non-contact level measurement sensor	NL-01
Dust tube accessory	NL-01/DT
Swivel mounting bracket	NL-01/SB

Software menus

- Home
General information regarding the NL-01.
- Set 4 mA
0.50m
Enter the distance that corresponds to the 4 mA output value.
- Set 20 mA
35.0m
Enter the distance that corresponds to the 20 mA output value.
- Set Relay 1
3.0m
Change the distance at which Relay 1 activates.
- Set Relay 2
0.5m
Change the distance at which Relay 2 activates.
- Update
0.1 sec
Change the update rate to suit the application.
- Filtering
ON
Select between normal operation and filtered output.
- Failsafe
3.6 mA
Set the failsafe condition of the 4...20mA range for alarm indications.

AGENT DETAILS



NEWCO Instruments CC
 Tel +27 (0) 11 768-2509
 Fax +27 (0) 86 725-4563
 E-mail jaco@newcosensors.co.za
 Physical No. 1 Stone Hill, 28 Serissa Avenue, Roodekrans Ext. 2, Gauteng, 1724, South Africa
 Postal PO Box 1446, Wilgeheuwel, 1736, South Africa